

**Acid-Rite® 450**  
Water pH Adjustment System

## Compact pH Adjustment System Conquers Pump Room Size Limitations

- Uses red sodium bisulfate tablets
- Enhances chlorine efficacy in water
- Low odor
- Low maintenance
- Controllable adjustment
- Footprint of Unit:  
14" wide x 20" long x 44" high



Stacking cartridge included for additional dial-in capability.



Water pH Adjustment System

A compact and effective alternative to bulky liquid acid systems. Utilizing red Acid-Rite sodium bisulfate tablets, the feeder system fits easily into the pump room making it a convenient and more manageable option for acid adjustment.

**Call 1.800.245.2974 for a FREE consultation or visit [acidrite.com](http://acidrite.com)**

# Acid-Rite Water Adjustment System Installation and Specification

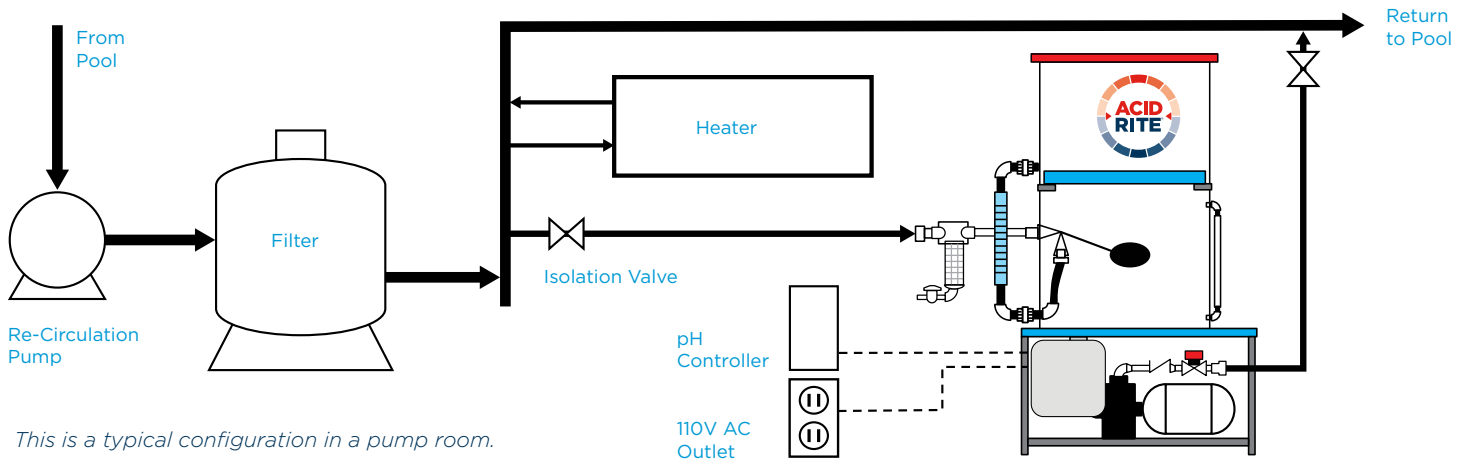

## Pool Size

- Inside: up to 300,000 gallons
- Outside: up to 200,000 gallons

## Acid-Rite Unit Size

- Flow Rate: 0-5 gpm
- Tablet Capacity: up to 45 lbs
- Supply/Discharge Pipe Size: 1"



## Acid-Rite Tablets

- 99.97% Sodium Bisulfate
- 3" diameter
- Red color for safety
- 45-lb pails

## No metering. No mixing. No contest.

Lightens the load on pool operators from safety, handling and maintenance, to creating a pleasant workplace environment. See for yourself.



	Safety	Handling	Maintenance	Material Compatibility and Corrosivity
 Water pH Adjustment System	Solid chemical made of sodium bisulfate with no dual containment	Easier to handle 45-lb resealable pails	Acid feeders rarely require cleaning or maintenance; no small tubing that can kink and crack	Tablets have low odor and are red in color to help eliminate inadvertent mixing of chemicals
 Muriatic Acid	Strong odor/fuming; potential liquid spills	55-gal drums weigh more than 500 lbs	Feed pumps need frequent repair and tubing can leak	Strong corrosive liquid with strong noticeable odor; leaking tubes or feed pumps can attack equipment room
 Granular Sodium Bisulfate	Bags are difficult to cut and empty; powder can accumulate on surfaces	50-lb bags are awkward and difficult to handle, not resealable	Feed pumps need constant repair and tubes plug regularly; mixing motors fail	Powdered acid and leaking tubes can attack mixing motors and equipment